

The logo for ALULOC, featuring the brand name in a bold, red, sans-serif font with a white outline, set within a red-bordered rounded rectangle.

ALULOC

The text 'Aluminium Ceiling Systems' in a white, sans-serif font, positioned below the ALULOC logo.

Aluminium Ceiling Systems

Aluminium Ceiling Systems

Aluloc Ceiling Suspension Grid is a very attractive, light weight, corrosion free grid with the speed of installation of the conventional steel roll form grid.

Aluloc is available in either 24mm flat face, 14mm flat face or 33mm wide top hat profile.

Aluloc has the following features:

- ▶ Easy installation, incorporating snap-lock main tee connection.
- ▶ Flush face for flush jointing.
- ▶ Spacers can be removed and re-installed without damage.
- ▶ Positive spacer/main runner connection.
- ▶ Fully adjustable system.
- ▶ Aesthetically pleasing with thin edges and hairline joins.
- ▶ Various finishes available, including white satin powdercoating, mill and natural anodise.

Aluloc has five different aluminium suspended ceiling systems to choose from:

- ▶ System FL24 -2, 24mm flush face 2 way exposed.
- ▶ System FL14 -2, 14mm flush face 2 way exposed.
- ▶ System TH33 -2, 33mm top hat profile 2 way exposed, with mitred spacer/main runner connections.
- ▶ System TH33 -1, 33mm top hat profile 1 way linear exposed.
- ▶ System FLTH33 -2, 24mm & 33mm combined 2 way exposed.

July 2002 Edition

© 2002 Luna & Valk Pty Ltd. The contents of this manual are covered by copyright laws. Reproduction of all or any part without written permission from the owner is prohibited. All illustrations and/or specifications are subject to change without notice.

Contents	Page
System FL24 - 2	2
System FL14 - 2	2
Connection Details	3
System TH33 - 2	4
System TH33 - 1	5
Standard Grid Modules	6
Product Selection Table	7
Product Profiles	8,9
Suspension Methods	10
Installation Instructions	11
Architectural Specification	12
Summary	13

System FL24 - 2 24mm Flush Face Ceiling System

System FL14 - 2 14mm Flush Face Ceiling System

System Description

A two way exposed system with either 24mm or 14mm wide flat face aluminium tee bar extrusion in both directions, comprising a main runner (either 3.6 or 4.2 met) with a slot pattern depending on grid module required, and spacer bar in opposite direction. The spacer length is also dependant on grid module required, ranging from 600mm to 1350mm. Suspension assembly consists of a spring adjustable suspension clip connected to 5mm suspension galvanised rod.

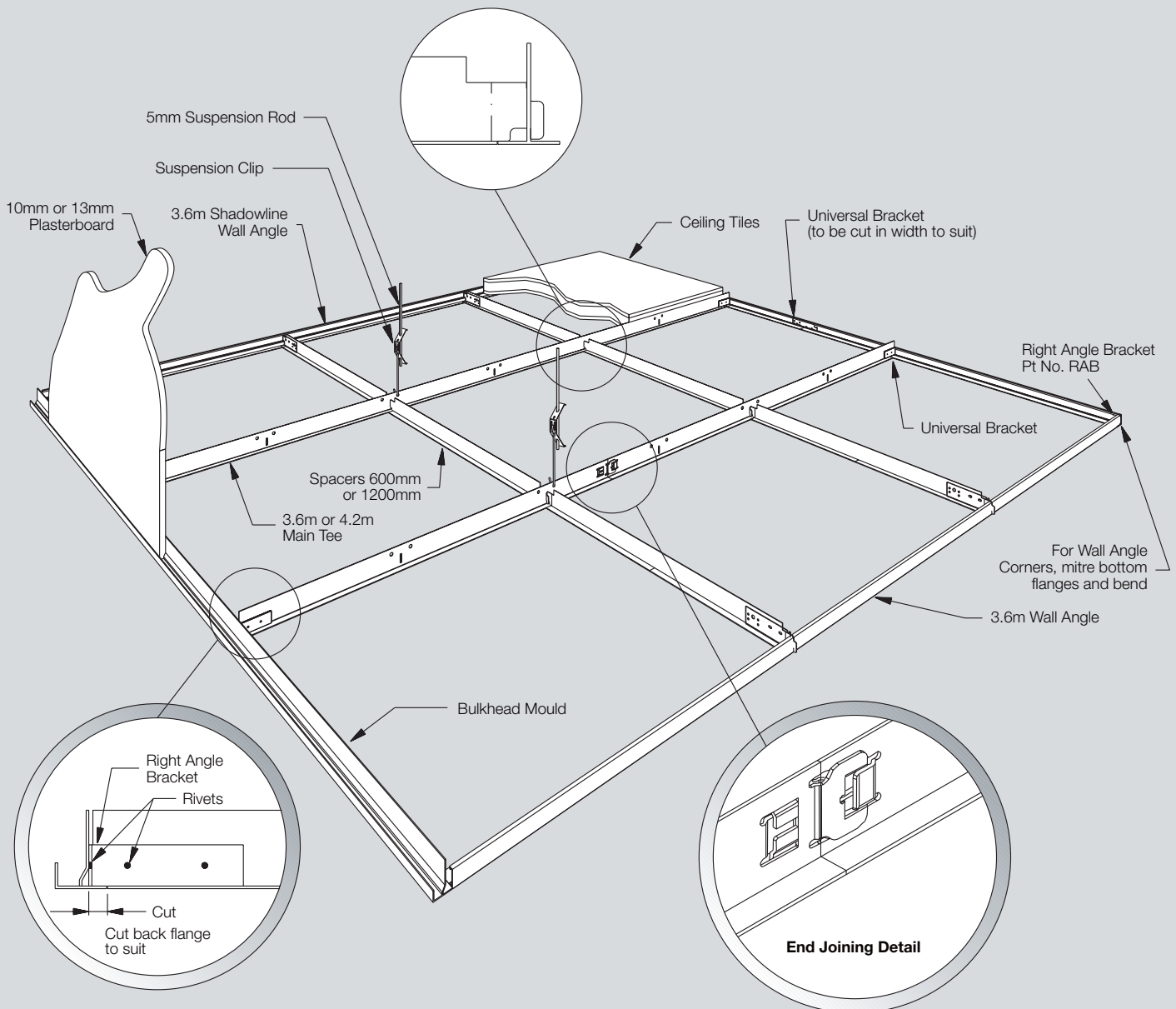

Connection Details

Wall Angle Joining

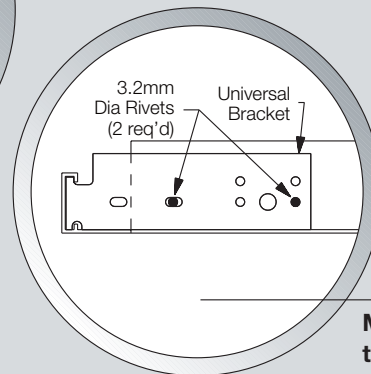
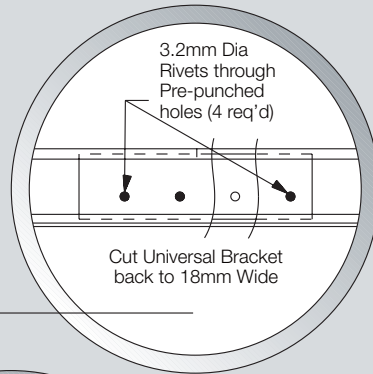

Main Tee or Spacer to Standard Wall Angle Mk 1

Spacer to Main Tee Joining

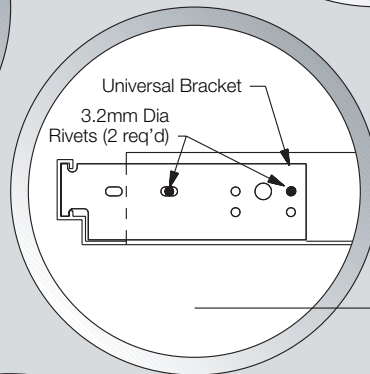
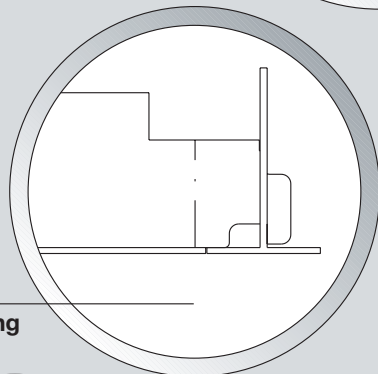

Main Tee or Spacer to Shadowline Wall Angle Mk 1

Main Tee Joining

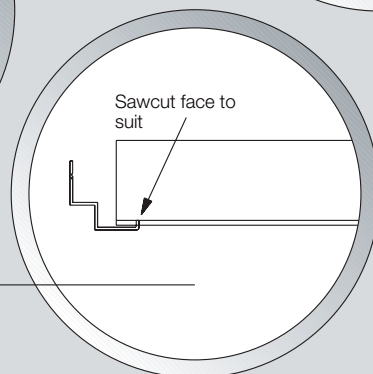
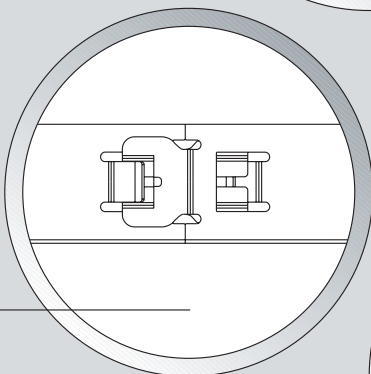

Main Tee or Spacer to Wall Angle Mk 2

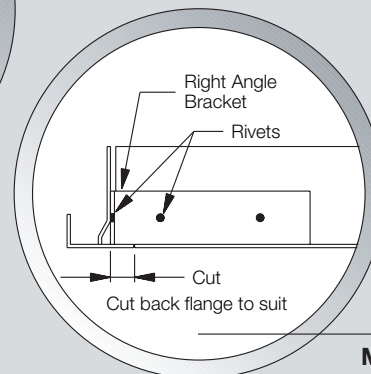

Main Tee or Spacer to Bulkhead

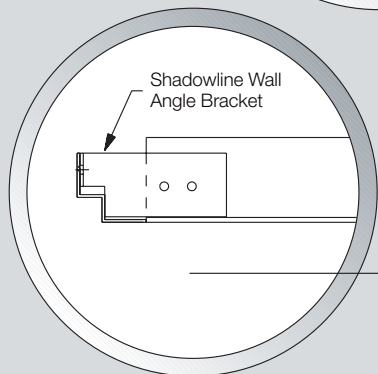

Main Tee or Spacer to Wall Angle Mk 3

System TH33 - 2

33mm Top Hat Ceiling System

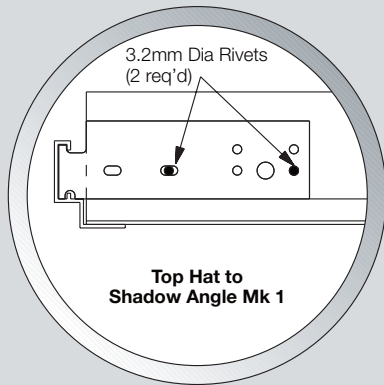

System Description

This system is a two way exposed system comprising a "Top Hat" profile - 33mm wide with a 6.5mm wide recess along the full length. Within the recess are longitudinal ridges to accept a 6mm bolt connecting a partition wall, if required. (As shown opposite)

The profile of the spacers are identical to the main runner and the connection of the two items are mitre cut to produce an aesthetically pleasing join, with uninterrupted recess lines.

The suspension assembly consists of either a spring or screw adjustable suspension clip connected to a 5mm galvanised rod.

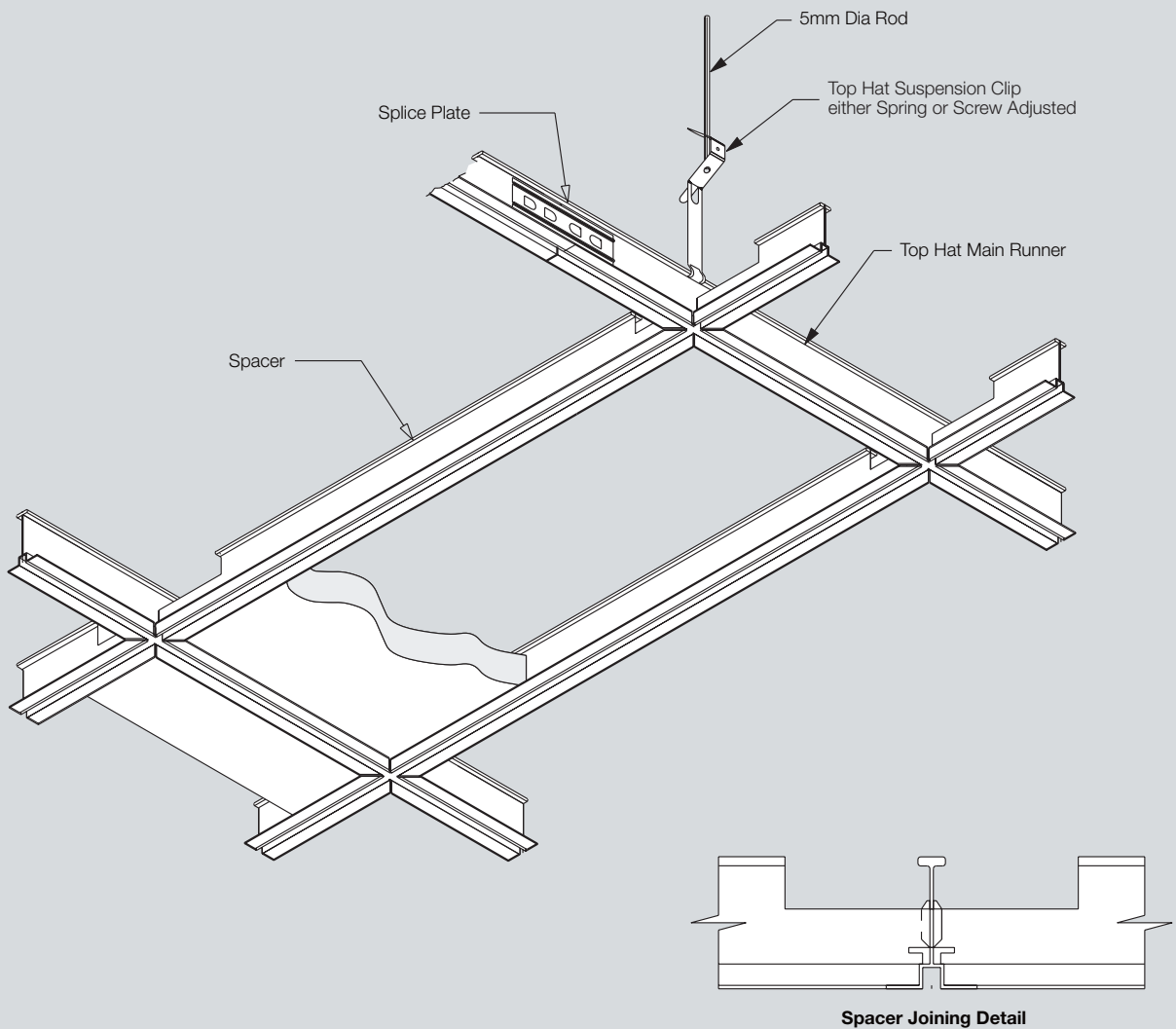

System TH33 - 1 33mm Top Hat One Way Linear

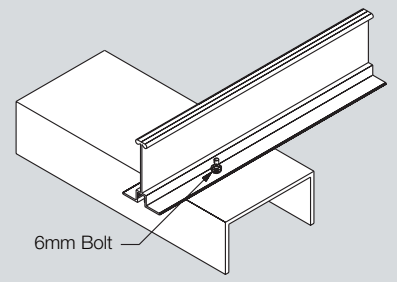
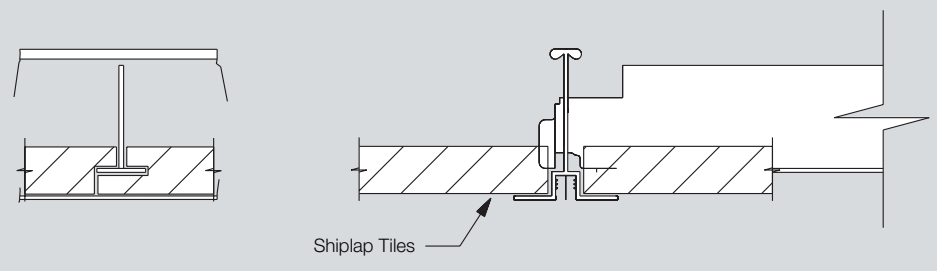
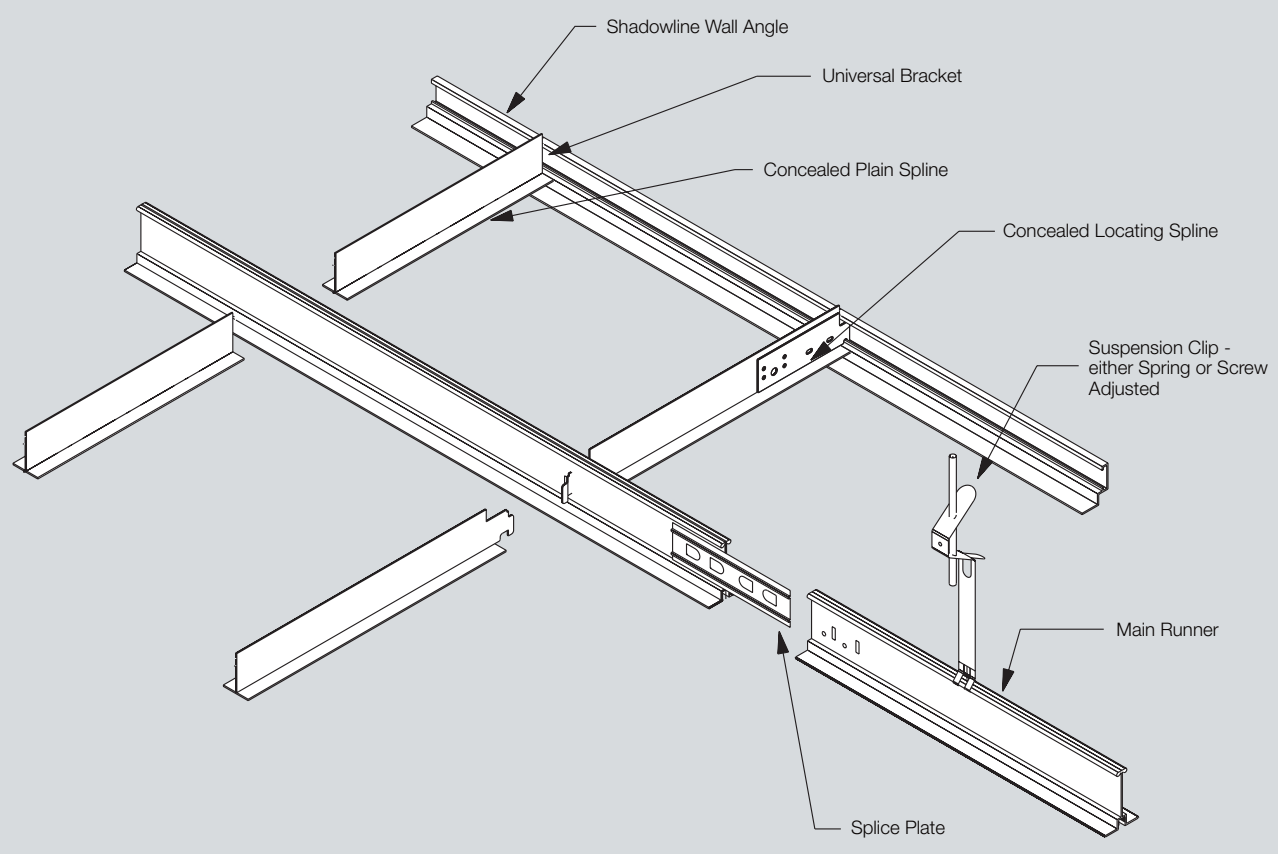

Partition Mounting Detail

System Description

This system is a one way exposed system comprising a one way linear "Top Hat" profile (identical to System TH33 - 2) main runner with locating splines to spread the main runner.

In a nominal 1200 x 400 Module configuration, with shiplap mineral fibre ceiling panels, aluminium locating concealed splines are spaced 1200mm apart, with 2 intermediate steel plain ended concealed splines, 400mm apart.

The suspension assembly consists of either a spring or screw adjustable suspension clip connected to a 5mm suspension galvanised rod.

Standard Grid Modules

System A

1200 x 600mm

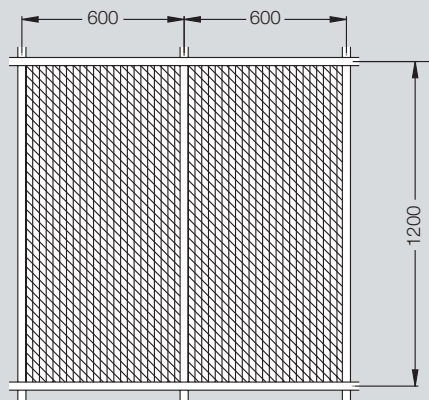

System B

1200 x 600mm

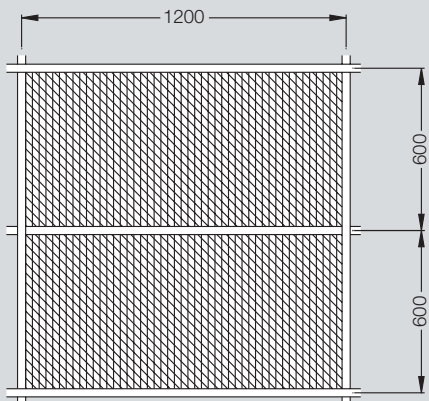

System C

1200 x 600mm

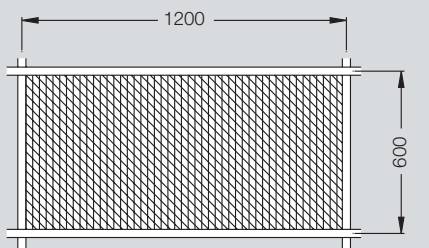

System D

600 x 600mm

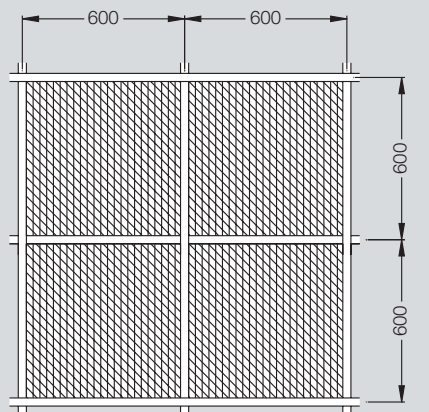

System E

1200 x 400mm

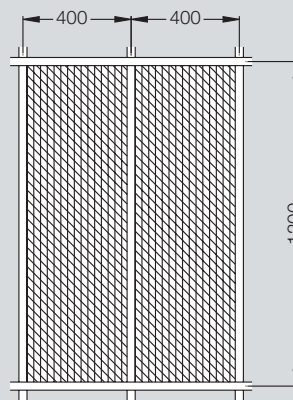

System F

1350 x 450mm

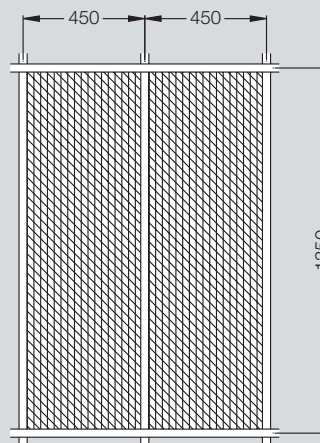

System G

600 x 600mm

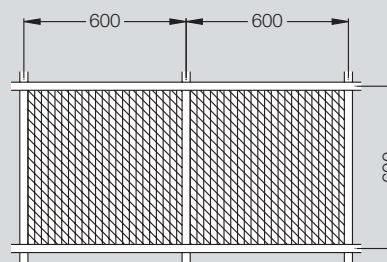

Direction of Pultrins

All dimensions shown
in millimetres.

Product Required

System	Components Required	Suspension Module
System A	Main Runner - 300mm slot spacing Spacer - 1200mm	1200 x 1200
System B	Main Runner - 300mm slot spacing Spacers - 1200mm centre slot Spacers - 1200mm	1200 x 1200
System C	Main Runner - 300mm slot spacing Spacers 600mm	1200 x 600
System D	Main Runner - 300mm slot spacing Spacers - 1200mm centre slot Spacers - 600mm	1200 x 1200
System E	Main Runner - 200mm slot spacing Spacers - 1200mm	1200 x 1200
System F	Main Runner - 225mm slot spacing Spacers - 1350mm	900 x 1350
System G	Main Runner - 300mm slot spacing Spacers - 600mm	1200 x 600

Note

- 1 All systems suitable for plasterboard, fibreglass or mineral fibre panels to a maximum weight of 10kgs per m².
- 2 Plaster Acoustic tiles (20kgs per m²) can only be used in System G.
- 3 Suspension assembly to be at 1200mm maximum spacing along all main runners.
- 4 All light fittings are to be supported on main runners with extra hangers.

Product Profiles

Main Runners

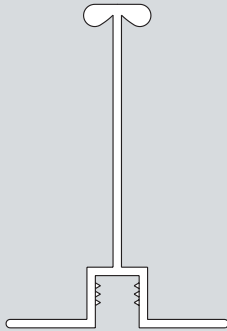
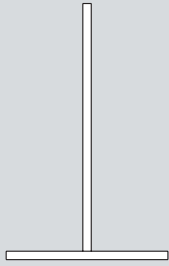

Part Number	Product Description	Approx Weight per piece (kg)
AMT4230	24 x 38 x 4200 - 300 slot spacing	0.865
AMT3610	24 x 38 x 3600 - 100 slot spacing	0.742
AMT3615	24 x 38 x 3600 - 150 slot spacing	0.742
AMT3630	24 x 38 x 3600 - 300 slot spacing	0.742
ANMT3630	14 x 38 x 3600 - 300 slot spacing	0.608

Part Number	Product Description	Approx Weight per piece (kg)
ATMT3630	33 x 48 x 3600 - 300 slot spacing	1.303

Spacers

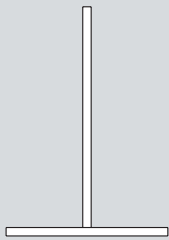

Part Number	Product Description	Approx Weight per piece (kg)
AS06	24 x 24 x 600	0.095
AS12	24 x 34 x 1200	0.230
AS12C	24 x 38 x 1200 centre slot	0.230
AS13	24 x 38 x 1350	0.278
ANS06	14 x 24 x 600	0.076
ANS12	14 x 37 x 1200	0.203

Bulkhead

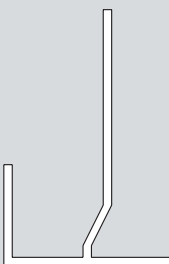

Part Number	Product Description	Approx Weight per piece (kg)
AUBH36	25 x 38 x 3600	0.900

Product Profiles

Wall Angels

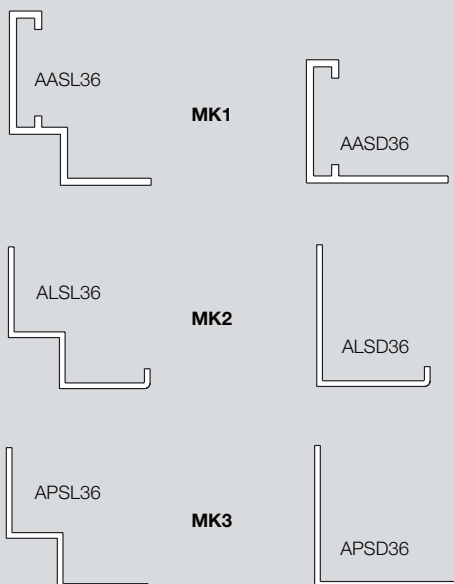

Part Number	Product Description	Approx Weight per piece (kg)
AASL36	25 x 31 x 3600 - shadow	0.796
AASD36	25 x 22 x 3600 - standard	0.684

ALSL36	25 x 27 x 3600 - shadow	0.601
ALSD36	25 x 20 x 3600 - standard	0.540

APSL36	25 x 25 x 3600 - shadow	0.569
APSD36	25 x 19 x 3600 - standard	0.500

Accessories

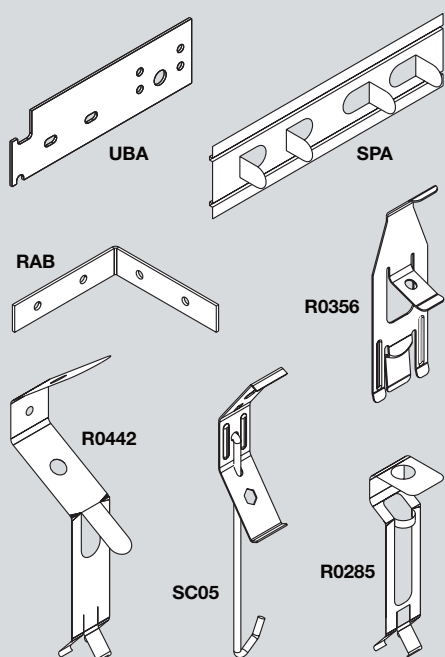

Part Number	Product Description	Approx Weight per piece (kg)
RAB	Right Angle Bracket	0.012
R0122	M6 x 5.2 Galv. Rod thread one end	-
R0285	Thread Adjustable Suspension Clip	0.032
R0356	Spring Adjustable Suspension Clip	0.029
R0442	5mm Spring Suspension Clip	0.016
R0826	M6 Nut	0.002
SC05	5mm Spring Suspension Clip	0.019
SPA	Splice Plate	0.013
UBA	Universal Bracket	0.018
WR05	5mm dia. x 3600 Galv. Rod	0.544

Material Specifications

The product profiles are extruded aluminium alloy 6063 temper T5 as per AS1866 - 1986.

Exposed faces are painted, powdercoated or anodised.

Length tolerance - main runner and spacer ± 0.250 mm.



Recommended Suspension Method

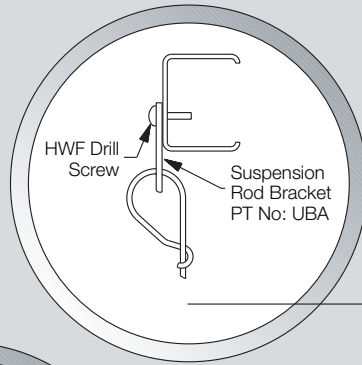

Suspension from Steel Beam

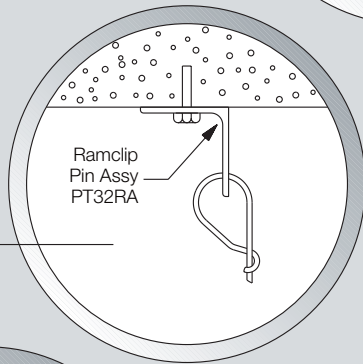

Suspension from Concrete

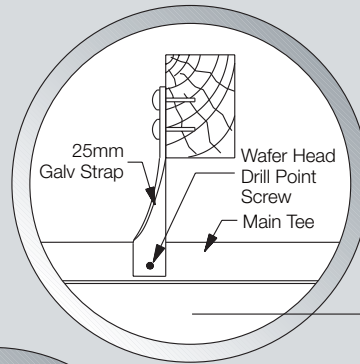

Suspension from Timber Joist

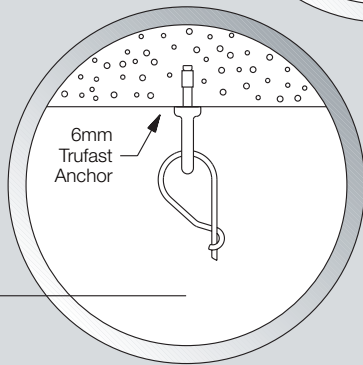

Suspension from Concrete

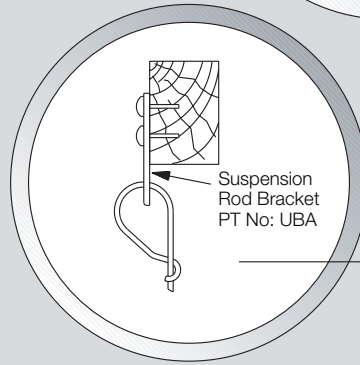

Suspension from Timber Joist

Suspension to Main Runner

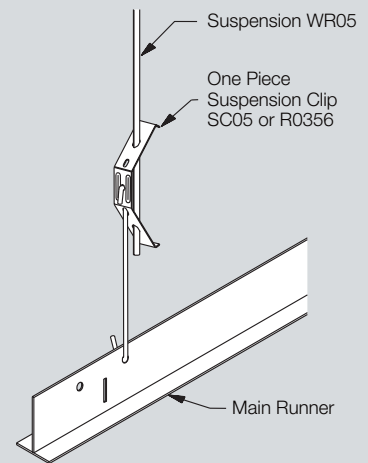
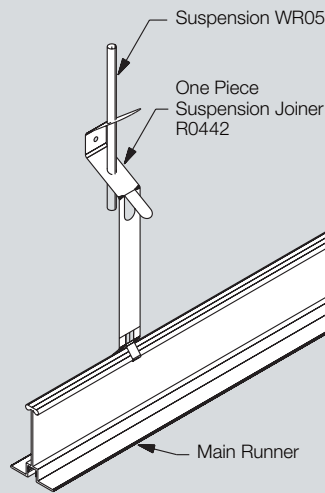
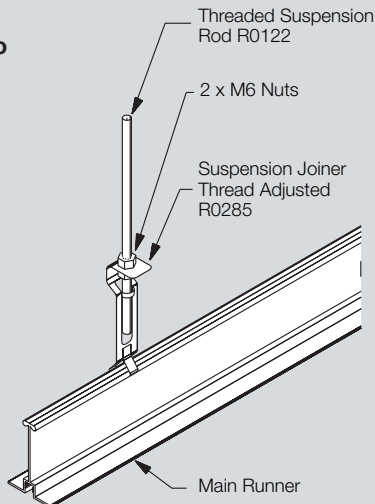

Installation Instructions

- 1** The main runner is to run at right angles to the support purlins.
- 2** Lay out ceiling grid module to datum as shown on architects drawings, and it is advisable to have equal cut tiles at perimeter walls, ie margins are equal on opposite sides if possible. Margin tile must be less than the size of the tile module.
- 3** Establish levels, minimum drop to be 150mm. Mark each wall to the correct height of the ceiling.
- 4** Attach wall angle. Mitre corners for a more attractive appearance. Fit joiner at angle joins, and corners. Fix angle to wall with suitable fasteners at 600mm maximum spacings.
- 5** Use string line or laser to achieve correct level between wall angles, and also to “square up” main tees off walls.
- 6** Fix hangers along supporting members (ie purlins, trusses, concrete, etc) at 1200mm maximum along proposed main runner runs, in locations to suit the grid module selected. (Refer standard grid layouts)
- 7** Cut hanger rods to 50mm shorter than ceiling height. The hanger assembly is to withstand without failure a load of 1.4kn or 143kgs, as required by AS/NZS2785:2000. Fit suspension clips to each rod.
- 8** Cut first main runner to length (if necessary) and attach to wall angles as follows:
 - a** If attached to Mark 1 wall angle, fit universal bracket at one end and roll into wall angle.
 - b** If attached to Mark 2 wall angle, notch or saw cut one end to suit lip on protruding leg angle.
- 9** Fit splice plate or universal bracket into main tee utilising prepunched holes, if more than one length required. Rivets to be used to join universal brackets to main runners, where as in the case of splice plates, the tabs are passed through the slots and tabs folded towards the join, leaving a hairline connection. Temporarily fix hanger clip to main tee at approximate level. Main tee can be adjusted vertically with use of the suspension clips.
- 10** Fully erect all main runners in correct plane spaced at either 600mm or 1200mm, 1350mm, depending on spacers used, and suitably attach to wall angles as described in step 8 above.
- 11** Measure and cut first run of margin spacers and attach one end to main runner through slot and other end to wall angle as described for main runners.
- 12** Fit second run of spacers ensuring that end of spacer is fitted correctly and on correct side of adjacent spacer, ensuring positive locking of both spacer connections into the main runners.
- 13** Repeat step 12 until all spacers are fitted, including margin spacers. Level and align the grid. The suspension clips can be adjusted to either a string line or laser.
- 14** The ceiling grid is now ready for the light fittings to be installed, and supported on the main runners only. Air conditioning grills and ceiling tiles can also be installed. Additional suspension points must be used where specified to carry light fittings and /or ceiling attachments.

Please Note

The suspension system is designed and tested to carry the weight of the ceiling only. Additional loads are not to be placed upon or carried by the suspension system.

Architectural Specification

General

The contractors responsibility is to supply all necessary material, labour and equipment for the installation of the Aluloc aluminium ceiling system, as indicated on the architectural drawings.

Material

The Aluloc aluminium ceiling system shall be as manufactured by Luna And Valk Group Pty Ltd in a finish as required, either standard powdercoat satin (app 20% gloss) white, mill finish or natural anodise. All material shall meet the requirements of Australian Standard AS2785 - 1985 - suspended ceilings - design installation.

Grid Module

The grid module shall be either 600 x 600, 1200 x 400, 1200 x 600 or 1350 x 450 or as specified.

Perimeter Detail

Either one of three perimeter wall angle (refer product profiles, page 9) profiles can be used with any of the Aluloc aluminium ceiling systems.

- 1 Where exposed members of the grid come into contact with the wall angle, Mark 1, it is advisable (for seismic purposes) to use the universal bracket (# UBA), to ensure the grid and the wall trim provide a flush finish.
- 2 Where exposed members of the grid come into contact with the lipped wall angle, Mark 2, these members must be cut in or notched onto the lip of the wall angle protruding leg.

Installation

The main runner shall be supported by 5mm soft galvanised rod, for all systems via a suspension clip, accurately levelled and spaced at a maximum 1200mm centre along the main runner. 600mm maximum inwards from the wall angle, and 150mm maximum from the main runner join.

Main runners to be separated withmm spacers, and the spacers spaced atmm centres to form amm xmm grid module. Spacers shall intersect main runners and be positively locked together and provide a flush finish for lay - in panels / tiles.

Wall angle shall be securely attached to the wall with suitable fasteners spaced at 600mm maximum, providing a level edge.

All suspension hangers, main runners and spacers shall be spaced so that the design ceiling load is not exceeded, or as may be required to prevent deflection in excess of 1/360 of the span of the main runner or spacers. Extra hangers are to be provided for light fittings, air conditioning units, etc, that are supported by the grid system.

Down bracing shall be incorporated in ceiling systems installed adjacent to openings or as required to prevent sudden uplift caused by external wind forces.

Tile hold down clips shall be used as required.

Summary

Aluloc Aluminium Ceiling System is manufactured and tested in accordance with the following standards:

AS/NZS2785:2000 - Suspended ceilings - design and installation.

AS1866 - 1986 - Aluminium & aluminium alloys - extruded rod, bar, solid and hollow shapes.

AS1664 - 1979 - SAA aluminium structures code.

AS1170.4 - 1993 - Minimum design loads on structuring part 4: Earthquake loads.

Testing Approvals

System FL24 - 2 - Testing of Suspended Ceiling Frames - Reference number C940705. Conducted by Department of Civil and Environmental Engineering, The University of Adelaide.

System FL24 - 2 - Static Testing of System Connections (Seismic Loads) - Reference number C200101. Conducted by Department of Civil and Environmental Engineering, The University of Adelaide

System TH33 - 2 - Testing of Suspended Ceiling Frames - Reference number C981006. Conducted by Department of Civil and Environmental Engineering, The University of Adelaide.

Guarantee

This is to guarantee that "Aluloc" Aluminium exposed grid manufactured by Luna and Valk Group Pty Ltd is free from defects directly attributed to the manufacturing faults for a period of 10 (ten) years providing the materials are installed (and the components used are those specified) and maintained in compliance with Luna and Valk Group's recommendation. During this period, should materials be dismantled or removed by any person not approved by Luna and Valk then this guarantee becomes null and void.

Registered Designs

Spacer Member for Aluloc - Registered Design No. 120439 (27/5/94).

Shadow Angle, Mark 1 - Registered Design No. 120438 (27/5/94).

Universal Bracket - Registered Design No. 120440 (27/5/94).

Top Hat 2 Way Exposed System - Registered Design No. 134032 (15/6/98)

Top Hat Spacer Member - Registered Design No. 134031 (15/6/98)

Top Hat Main Runner - Registered Design No. 134030 (15/6/98)

Bulkhead (Universal) - Reg. Des. Pending.

For further information

Luna & Valk Group Pty. Ltd.

ACN 007 728 341

79 South Terrace, Wingfield SA 5013

Telephone (08) 8268 6533

Facsimile (08) 8268 6238

International phone +61 8 8268 6533

email: enquiry@lunavalk.com.au

<http://www.aluloc.com.au>



Available from

